

# Technical data sheet



## Product features

### Fryer for fish electric 0,75 kW/l, 8 l counter top 230 V

<b>Model</b>	<b>SAP Code</b>	00006714
--------------	-----------------	----------



- Basin volume [l]: 8
- Drain: No
- Maximum device temperature [°C]: 190
- Minimum device temperature [°C]: 50
- Material: Stainless steel
- Heating location: Inside the tank
- Ignition: Electric
- Number of baskets: 1
- Basket size [mm]: 150 x 320 x 120

<b>SAP Code</b>	00006714	<b>Power electric [kW]</b>	3.400
<b>Net Width [mm]</b>	248	<b>Loading</b>	230 V / 1N - 50 Hz
<b>Net Depth [mm]</b>	516	<b>Basin volume [l]</b>	8
<b>Net Height [mm]</b>	313	<b>Number of baskets</b>	1
<b>Net Weight [kg]</b>	6.00	<b>Basket size [mm]</b>	150 x 320 x 120

# Technical data sheet



Technical drawing

Fryer for fish electric 0,75 kW/l, 8 l counter top 230 V

Model	SAP Code	00006714
-------	----------	----------

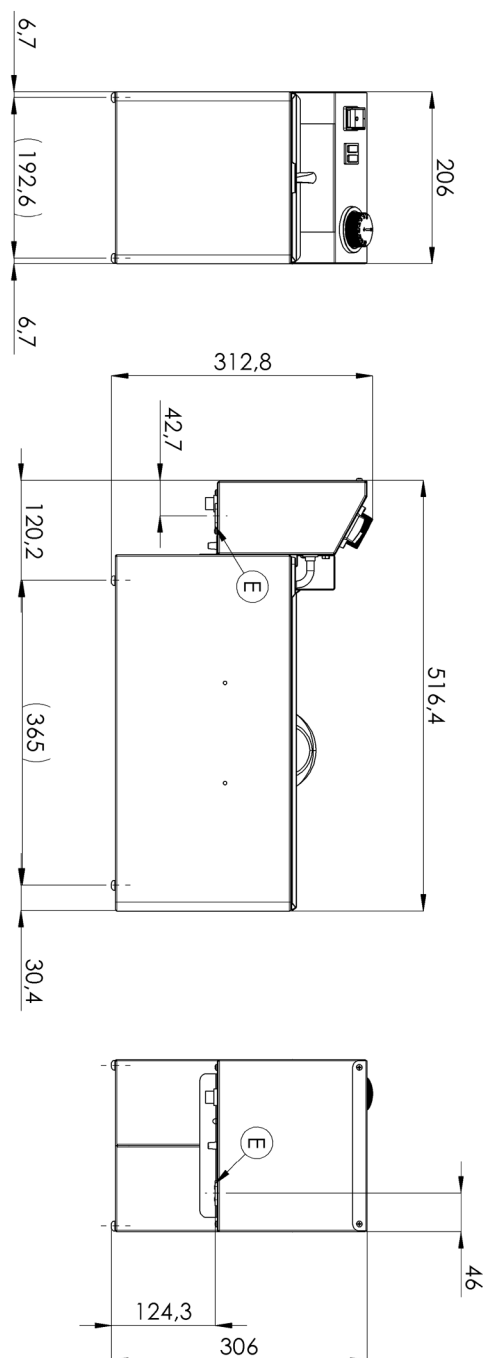

### Fryer for fish electric 0,75 kW/l, 8 l counter top 230 V

Model

SAP Code

00006714

1

#### All-stainless design

long life  
resistance of AISI 304 stainless steel material  
the material does not cut

- savings on service interventions
- easier and faster operation

2

#### Degree of protection of the control elements IPX4

maintenance-free system  
resistance to splash water  
long life

- savings on service interventions
- easy cleaning and maintenance of equipment

3

#### Effective cold zone

prevents food residues from burning  
there is no change in the taste of the oil

- longer oil life
- easy access and maintenance

4

#### Removable heating element

longer lifetime  
easy access

- fully removable electric box with heating element for convenient cleaning and servicing
- easy access even to corners and time saving

5

#### Removable container

stainless steel container with handles

- easier cleaning and handling
- dishwasher safe

6

#### Manipulation

easy portability

- flexibility in the kitchen, can be used for banquets

7

#### Prevention of spontaneous combustion

higher rear chimney

- safer heat dissipation and separation of oil and ventilation from the fryer

8

#### 2 thermostats

safety and working thermostat

- traffic safety
- prevention of spontaneous combustion
- Prevention of oil flashover

# Technical data sheet



## Technical parameters

### Fryer for fish electric 0,75 kW/l, 8 l counter top 230 V

<b>Model</b>	<b>SAP Code</b>	00006714
--------------	-----------------	----------

**1. SAP Code:**

00006714

**2. Net Width [mm]:**

248

**3. Net Depth [mm]:**

516

**4. Net Height [mm]:**

313

**5. Net Weight [kg]:**

6.00

**6. Gross Width [mm]:**

250

**7. Gross depth [mm]:**

650

**8. Gross Height [mm]:**

350

**9. Gross Weight [kg]:**

6.00

**10. Device type:**

Electric unit

**11. Construction type of device:**

Table top

**12. Power electric [kW]:**

3.400

**13. Loading:**

230 V / 1N - 50 Hz

**14. Ignition:**

Electric

**15. Protection of controls:**

IPX4

**16. Material:**

Stainless steel

**17. Indicators:**

operation and warm-up

**18. Worktop material:**

AISI 304

**19. Worktop Thickness [mm]:**

0.80

**20. Standard equipment for device:**

lid and basket

**21. Basin volume [l]:**

8

**22. Maximum device temperature [°C]:**

190

**23. Minimum device temperature [°C]:**

50

**24. Safety thermostat up to x ° C:**

235

**25. Adjustable feet:**

Yes

**26. Heating element material:**

AISI 304

**27. Number of baskets:**

1

**28. Basket size [mm]:**

150 x 320 x 120

# Technical data sheet



Technical parameters

Fryer for fish electric 0,75 kW/l, 8 l counter top 230 V

<b>Model</b>	<b>SAP Code</b>	00006714
--------------	-----------------	----------

**29. Heating element construction:**

Large surface area coiled heating element to extend its life and heat the oil bath evenly

**31. Heating location:**

Inside the tank

---

**30. Drain:**

No